



OLYMPIA

105\_SP\_3  
Assembly Instructions

Assembly  
Steps  
SP 3

GRANDO  
LUCE

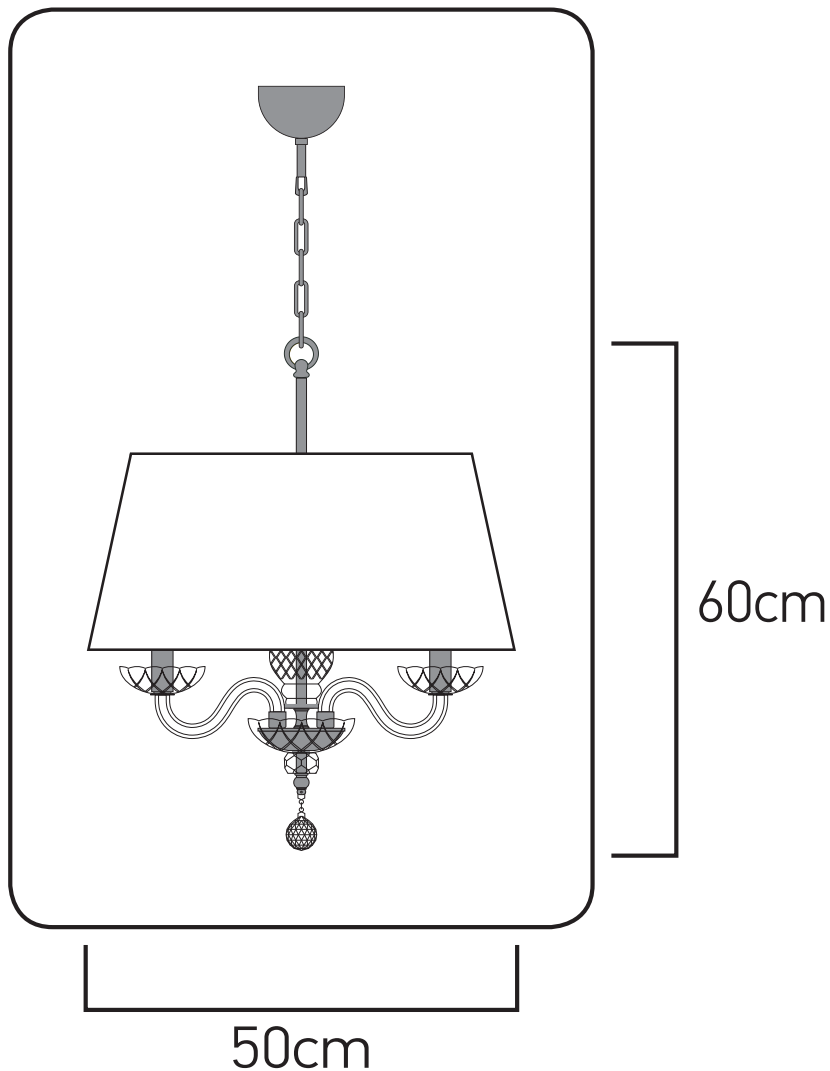

MIRSINI\_SP 3

# parts\_components

N°1 x 1

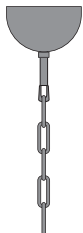

N°2 x 1

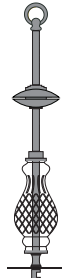

N°3 x 1



N°4 x 1



N°5 x 3

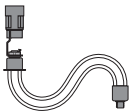

N°6 x 3



N°7 x 3



A x 1



reference	lamps	lamp Watt Max	A.C
105/SP 3	3 x E14	42 Watt	230V - 50Hz

	ΗΜΕΡΟΜΗΝΙΑ ΕΛΕΓΧΟΥ TESTING DATE	..... / ..... / .....	ΥΠΟΓΡΑΦΗ ΕΛΕΓΚΤΗ TEST OPERATOR
--	------------------------------------	-----------------------	-----------------------------------



DO NOT ASSEMBLE ANY GLASS PARTS THAT PRESENT CRACKS OR ANY OTHER DAMAGED CAUSED BY CARRIAGE OR WRONG PLACEMENT. A CAREFUL CHECK IS SUGGESTED. CLEAN WITH SOFT CLOTH OR MILD RISING AGENT WITH LOW TEMPERATURE WATER.  
 ΜΗ ΣΥΝΑΡΜΟΛΟΓΕΙΤΕ ΓΥΑΛΙΝΑ ΜΕΡΗ ΠΟΥ ΦΕΡΟΥΝ ΡΩΓΜΕΣ Ή ΑΛΛΕΣ ΖΗΜΙΕΣ ΑΠΟ ΜΕΤΑΦΟΡΑ Ή ΛΑΘΟΣ ΤΟΠΟΘΕΤΗΣΗ. ΚΑΘΑΡΙΣΤΕ ΜΕ ΜΑΛΛΑΚΟ ΠΑΝΙ Ή ΜΕ ΗΠΙΟ ΚΑΘΑΡΙΣΤΙΚΟ ΜΕ ΝΕΡΟ ΣΕ ΧΑΜΗΛΗ ΘΕΡΜΟΚΡΑΣΙΑ.

THIS DESIGN IS PROPERTY OF GRANDO LUCE AND IT IS FORBIDDEN TO COPY ANY PART OF THE DESIGN  
 ΑΥΤΟ ΤΟ ΣΧΕΔΙΟ ΕΙΝΑΙ ΙΔΙΟΚΤΗΣΙΑ ΤΗΣ GRANDO LUCE ΚΑΙ ΑΠΑΓΟΡΕΥΕΤΑΙ ΑΥΣΤΗΡΩΣ Η ΑΝΤΙΓΡΑΦΗ ΟΛΟΥ Ή ΜΕΡΟΥΣ ΑΥΤΟΥ

# STEP\_1

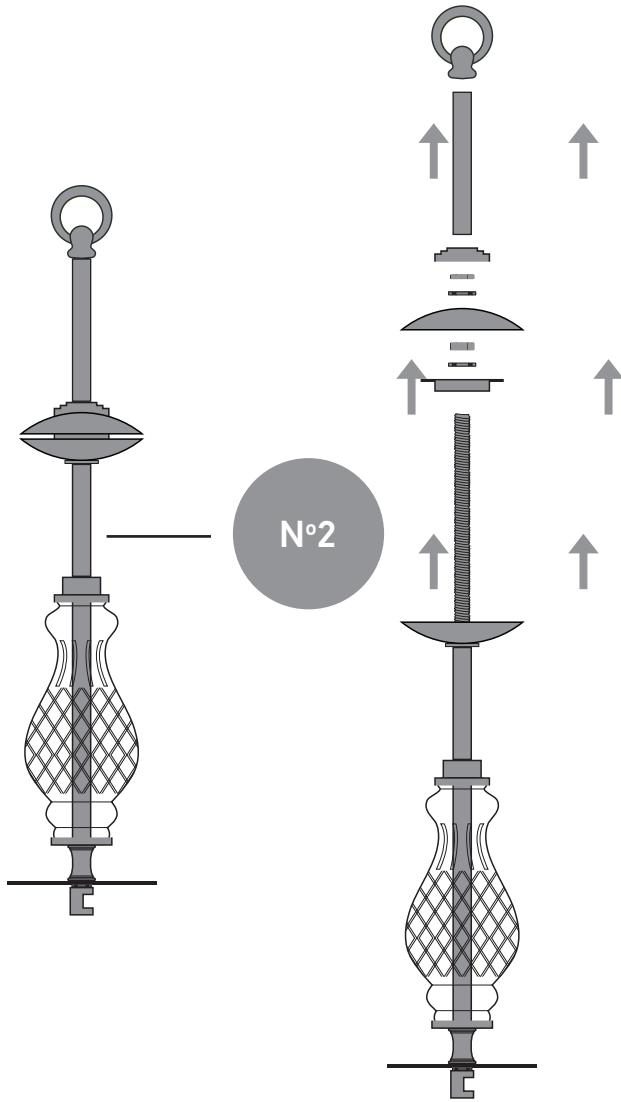

STEP\_2

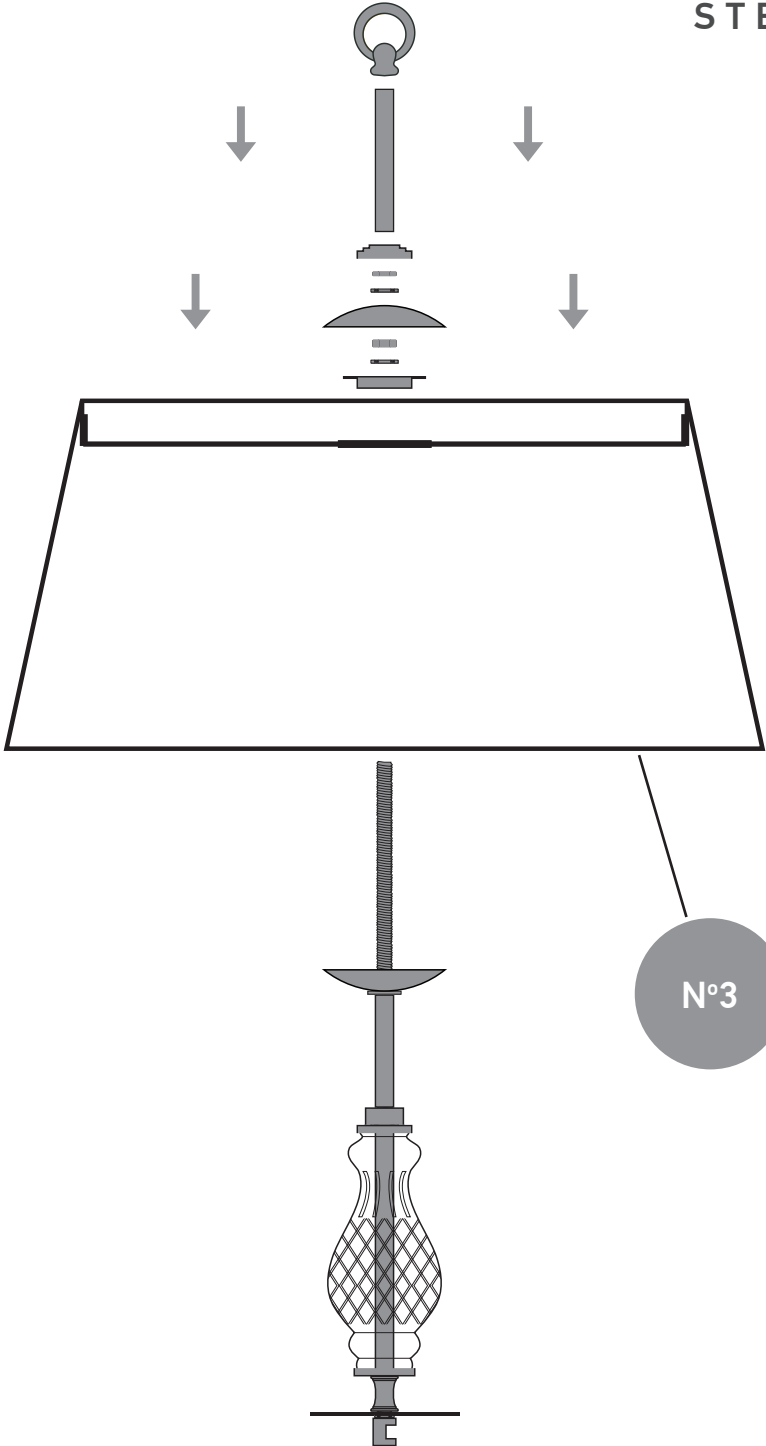

# STEP\_3

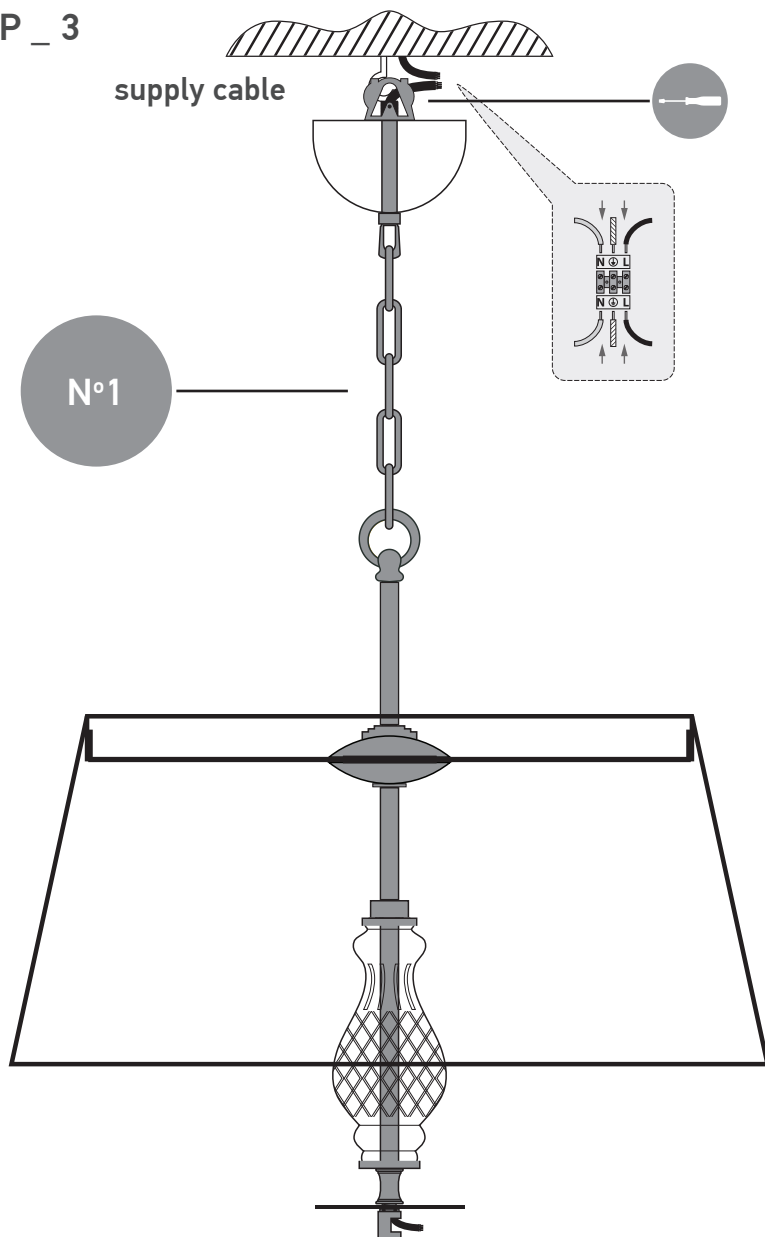

**WARNING:** fix the marked screws in the safety locking

STEP\_4

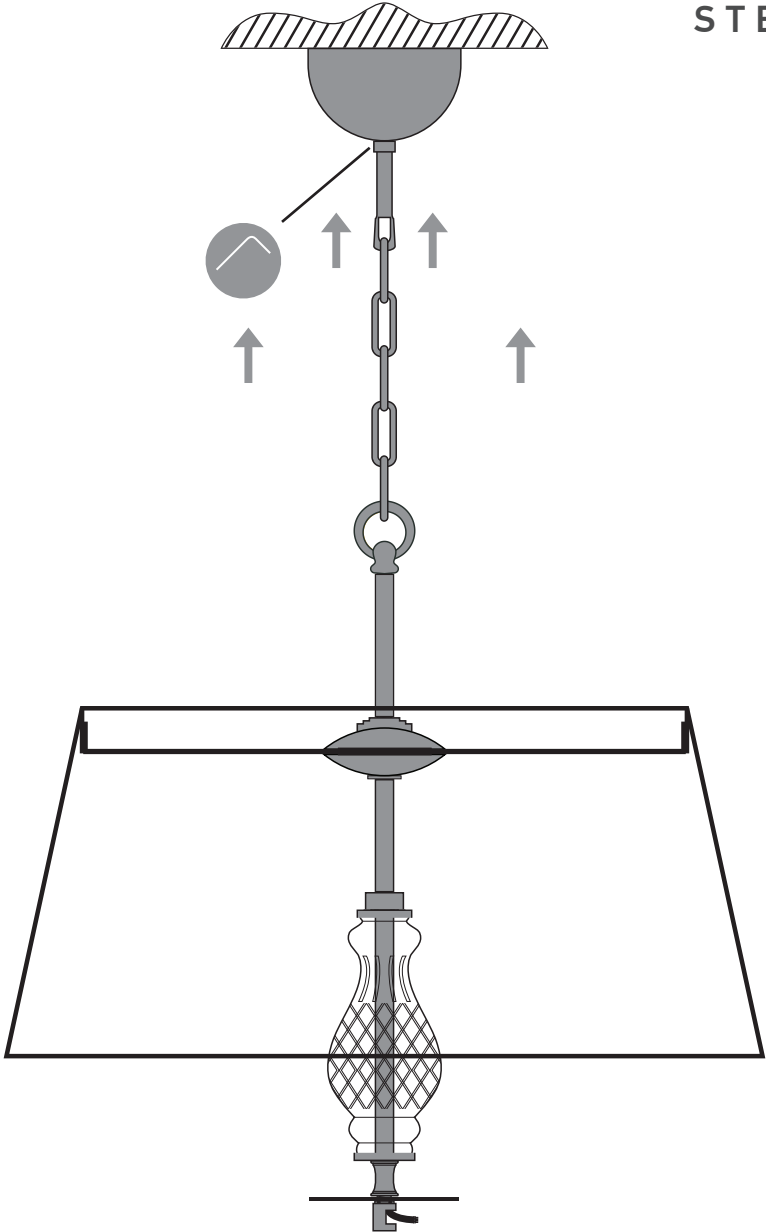

STEP\_5

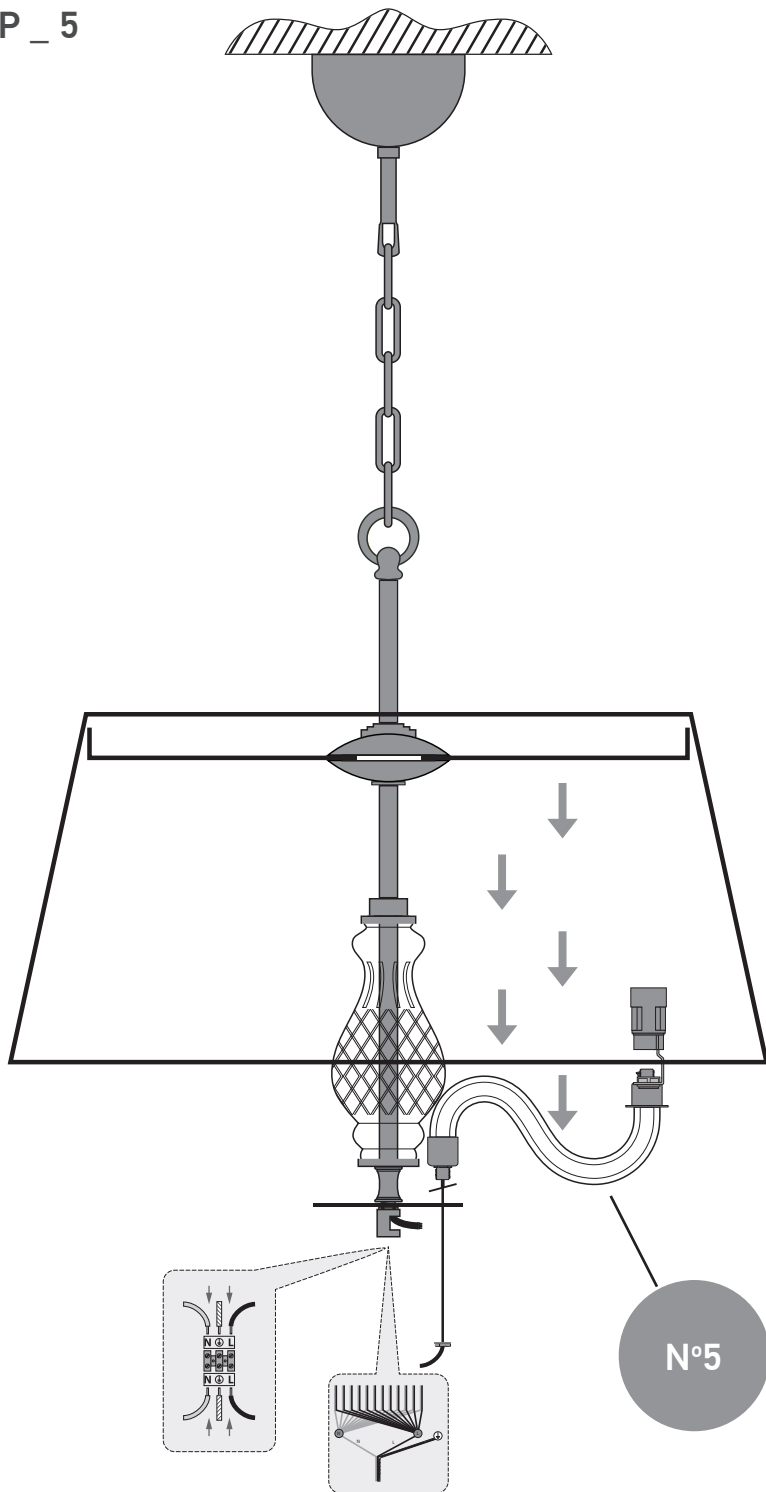



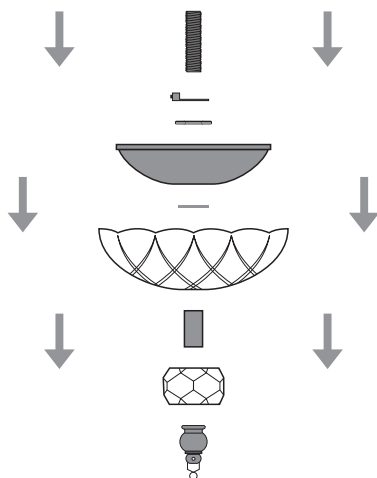
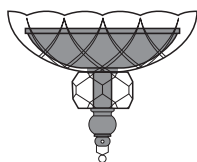

# STEP\_7

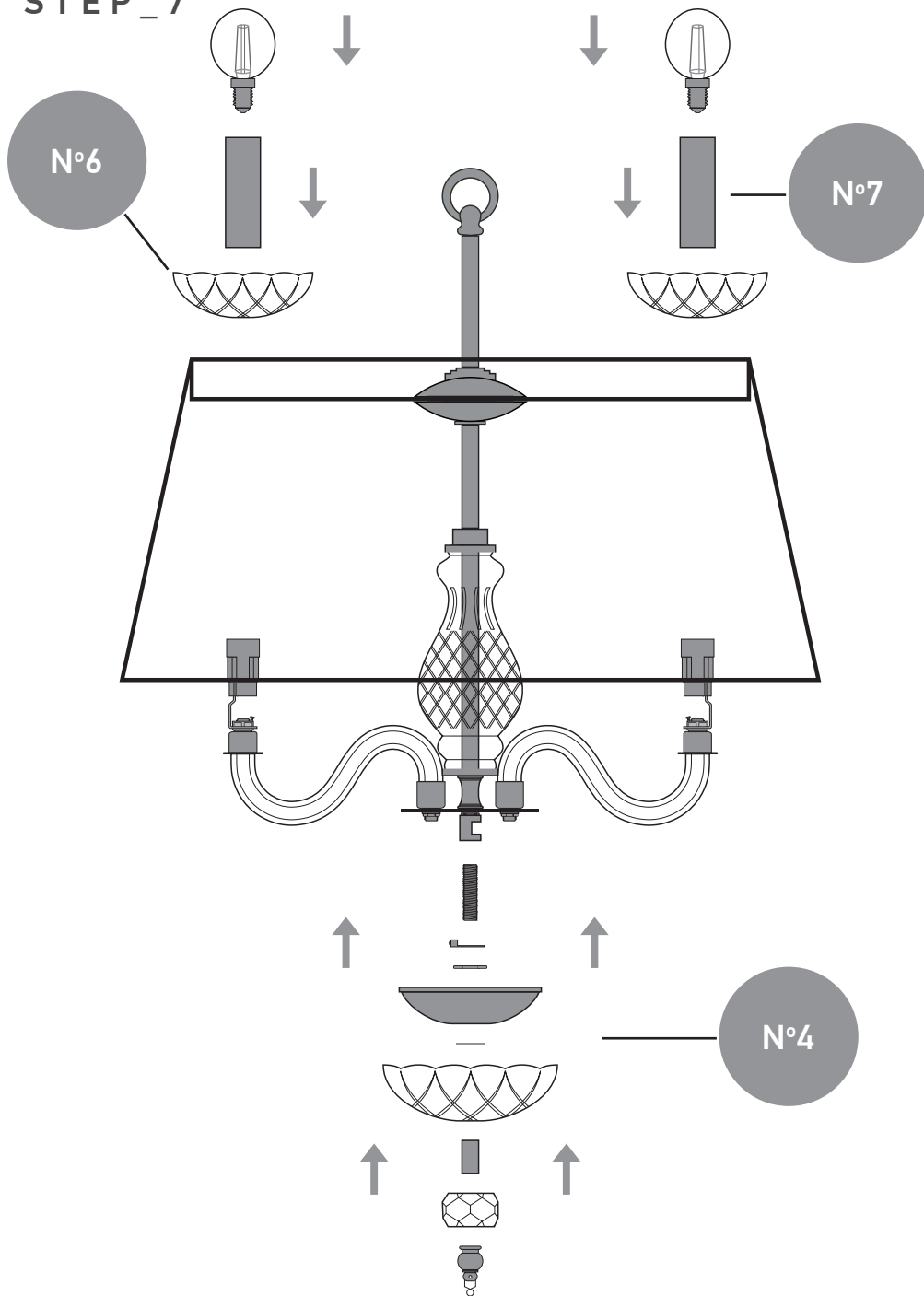

# DECORATION TRIMMINGS VIEW

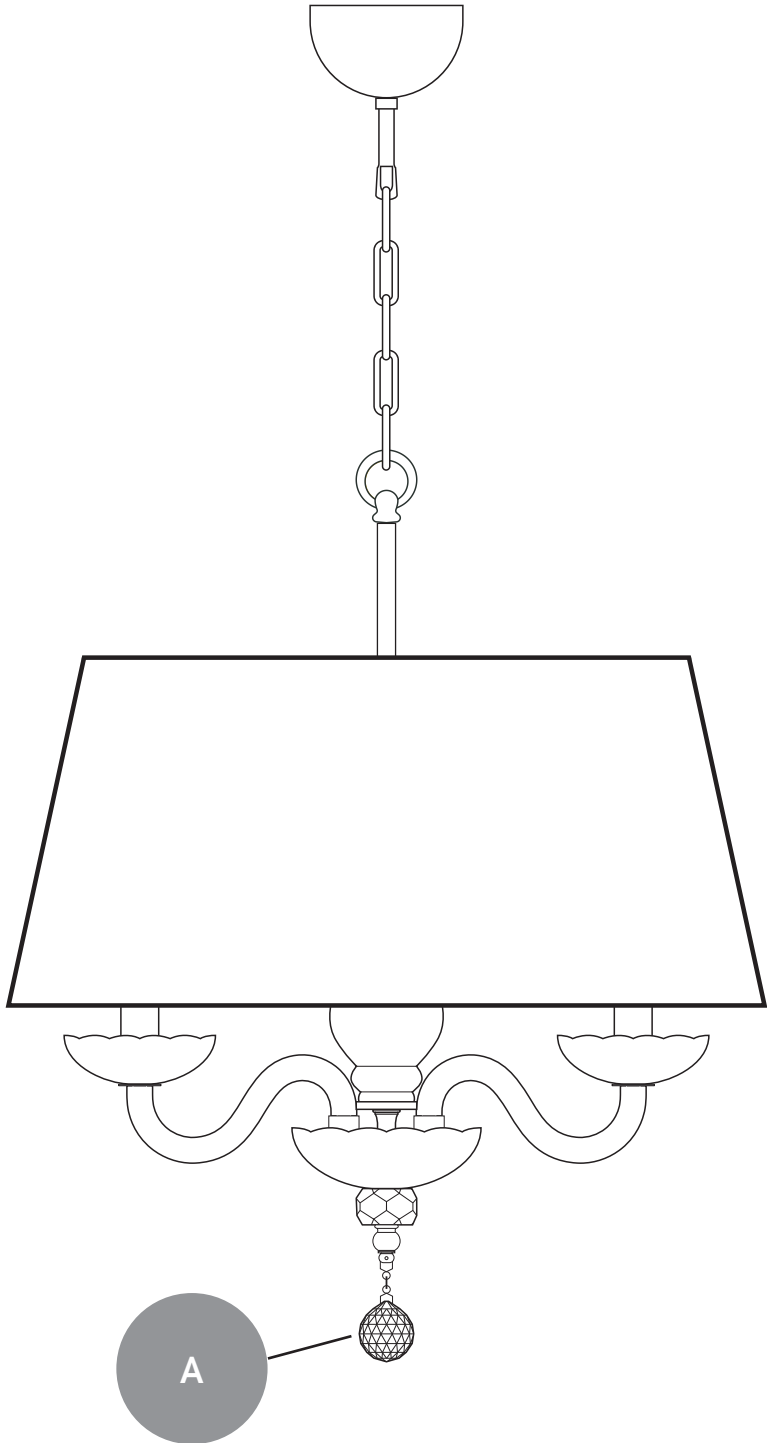



**MADE IN  
GREECE**

11 Karditsis str, 42100  
T +30 24310 76646  
info@grandoluce.com

Trikala, Greece  
F +30 24310 76696  
www.grandoluce.com